

THERMOSTATIC VALVES WITH PRESETTING

1. DESCRIPTION

Thermostatic valves with presetting allow distribution of the water flow to the radiator by means of a shaped body, thereby ensuring an optimum balance of the circuit. The valves are designed for thermostatic head assembly with either an iron connection or an interchangeable connection for copper, plastic and multilayer pipe - both available in 3/8" and 1/2" sizes.

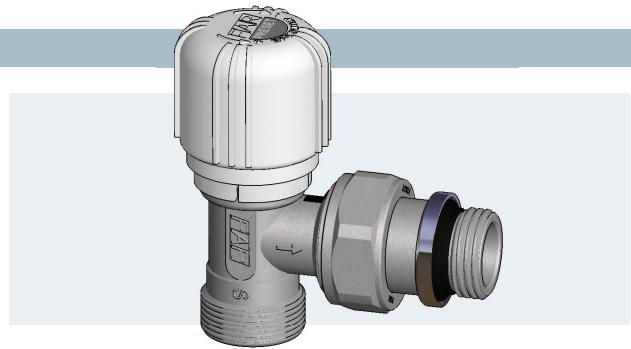

2. REGULATION

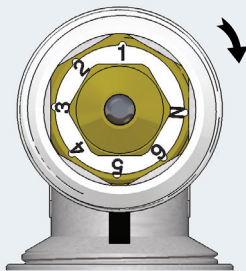

The shape of the adjustment body allows you to set a default value of flow resistance for each of the calibration positions.

The adjustment is made by removing the handle and turning the body so that the setting corresponds to the black reference notch. Settings are from 1 to 6, N indicates 'fully open'.

For ease of adjustment we recommend you use the plastic key provided inside the box and follow the steps below.

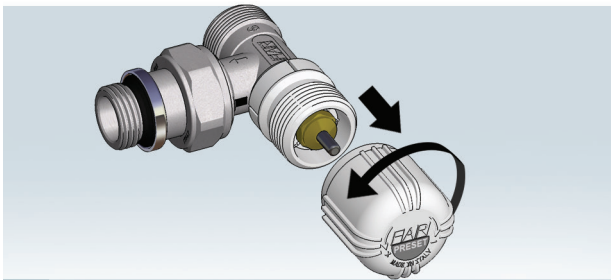

1. Unscrew the handle by turning counterclockwise.

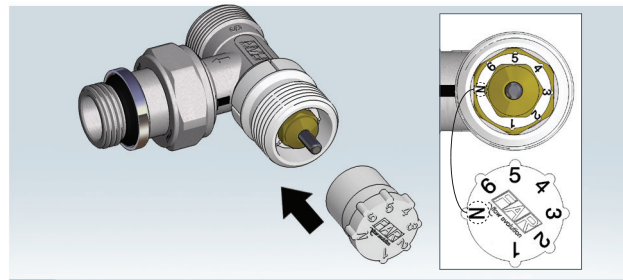

2. Insert the plastic regulation key by matching the letter N to the one on the valve.

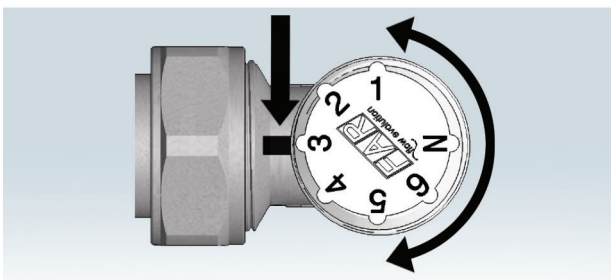

3. Turn the key clockwise or counterclockwise to position the valve at the required setting.

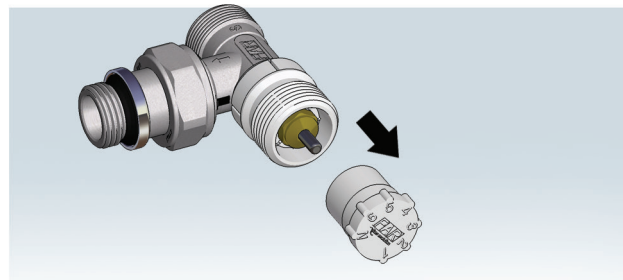

4. Remove the key and replace the handle or the thermostatic head.

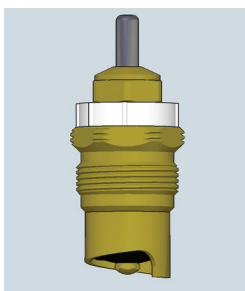

When sizing the system you should allow for the higher flow resistance and, through the presetting, assign appropriate flow resistance to the other circuits to obtain a balanced heating system. In using this type of regulation, every link of the system should always have the required flow rates.

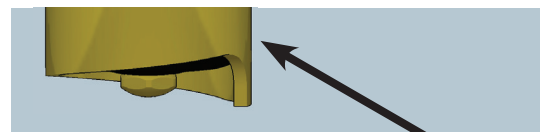

The special shape of the body regulates the passage of the fluid to the radiator.

When a thermostatic head is installed, the previous calibration will be maintained.

3. THERMOSTATIC HEAD

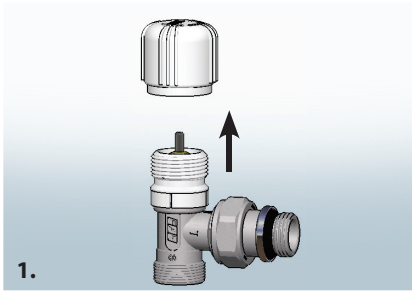

1. Unscrew the handle.

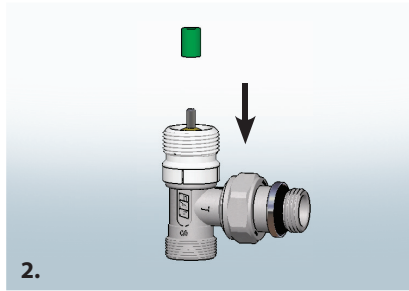

2. Insert the green extractor onto the steel pin.

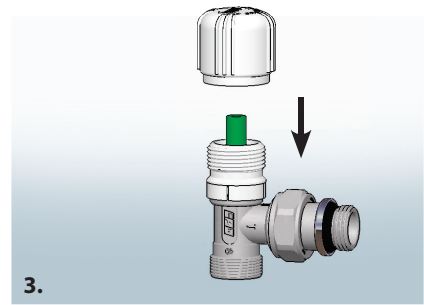

3. Screw the handle.

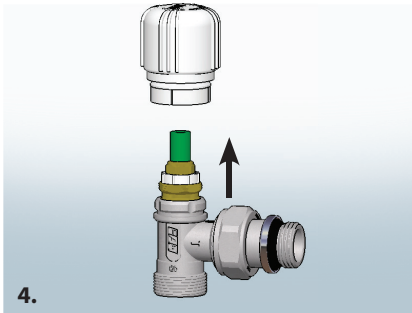

4. Remove the threaded plastic support.

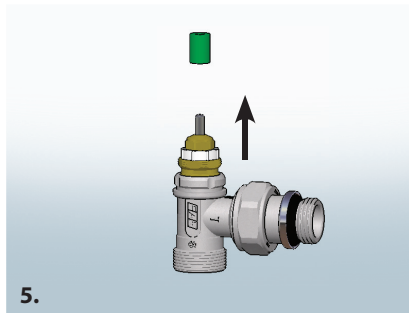

5. Remove the green extractor from the pin.

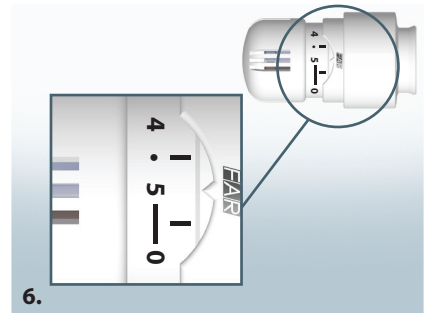

6. Set the temperature selector on n°5.

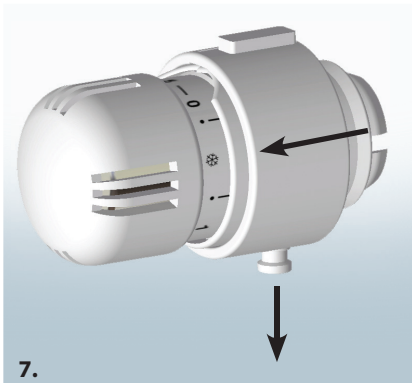

7. Pull the ring towards the selector and pull the locking key down.

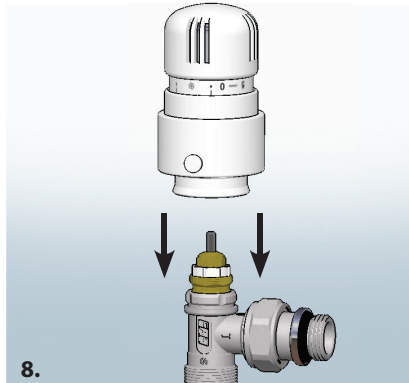

8. Place the head as shown in the diagram by matching the joints.

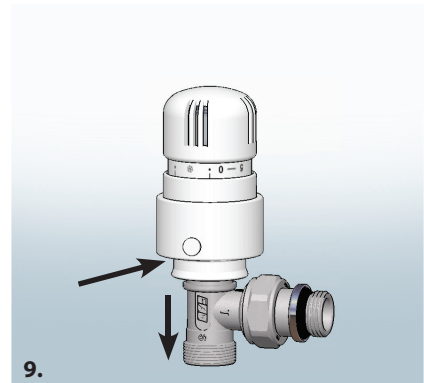

9. Push the ring towards the valve until the FAR logo is fully visible and press the lock button.

4. TECHNICAL FEATURES

Valve body:	CW617N brass
Shutter:	EPDM
Body:	CW614N brass
Spring:	AISI 302 steel
Pin:	AISI 302 steel
Handle:	ABS
Sealing O-rings:	EPDM
Sealing seat:	HPF
Union body:	CW617N brass
Tightening nut union:	CW617N brass
Nominal pressure:	16 bar
Max. temperature:	100°C
Usable media:	water, water with glycol

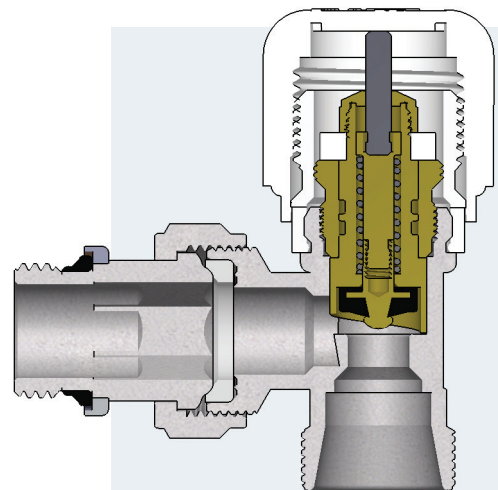

5 FLUID DYNAMIC FEATURES

The diagrams show the values of flow resistance in the various calibration positions in manual operation.

For each presetting position you can see the corresponding values of Kv, defined as the flow rate in m³/h that produces a flow resistance of 1 bar.

If you want to calculate the flow resistance in an analytical way, the formula to be used is as follows:

$$K_v = Q / \sqrt{\Delta p}$$

where Q is the flow rate flowing in the heating circuit and Δp the pressure difference.

1638 38 - 1648 38

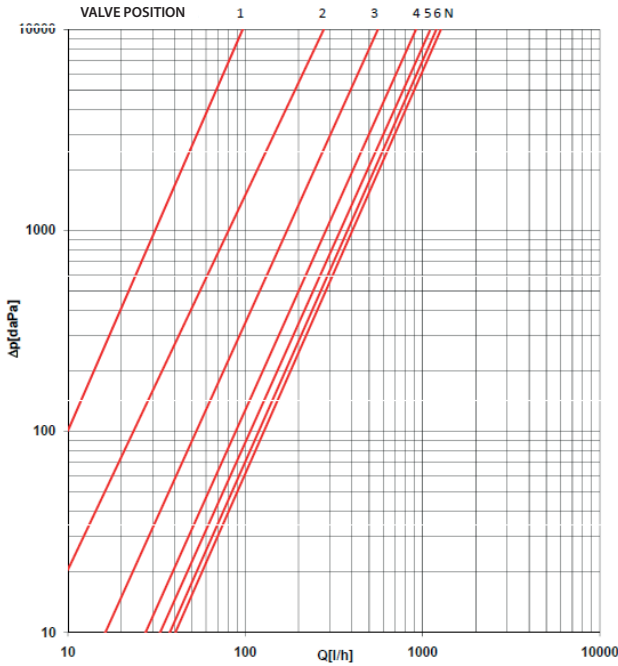

Position	1	2	3	4	5	6	N
Kv [m ³ /h]	0,097	0,28	0,56	0,92	1,1	1,19	1,2

1618 38 - 1628 38

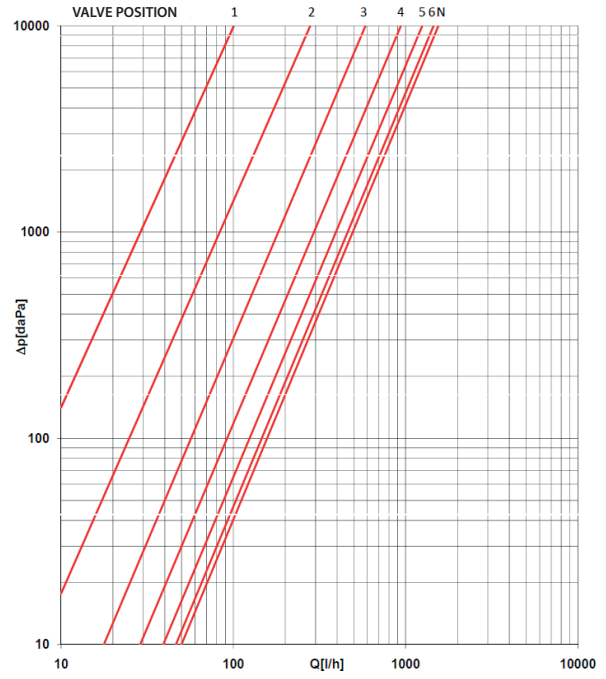

Position	1	2	3	4	5	6	N
Kv [m ³ /h]	0,1	0,28	0,58	0,93	1,24	1,45	1,49

1638 12 - 1648 12

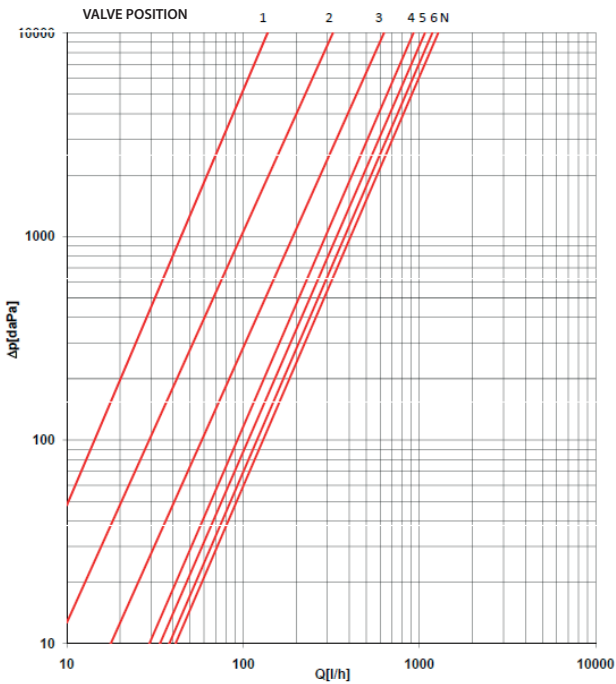

Position	1	2	3	4	5	6	N
Kv [m ³ /h]	0,12	0,32	0,63	0,92	1,1	1,18	1,2

1618 12 - 1628 12

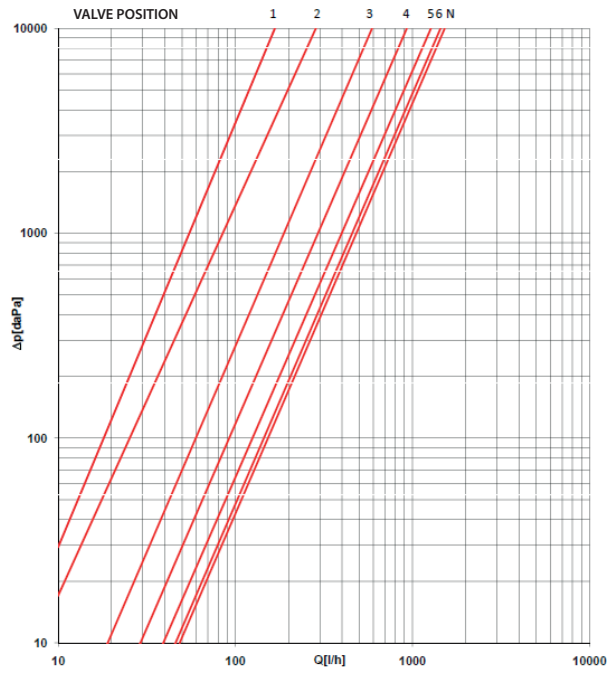

Position	1	2	3	4	5	6	N
Kv [m ³ /h]	0,16	0,28	0,56	0,92	1,27	1,44	1,52

Comparing the Kv values for 3/8" and 1/2" valves in straight and angled versions you can see that, for the initial adjusting positions, you obtain very similar Kv values, while for completely open positions the angle valves versions have a higher value of Kv.

After installing the thermostatic head on the valve, the flow resistance has been recalculated with curves with proportional band to s-2k.

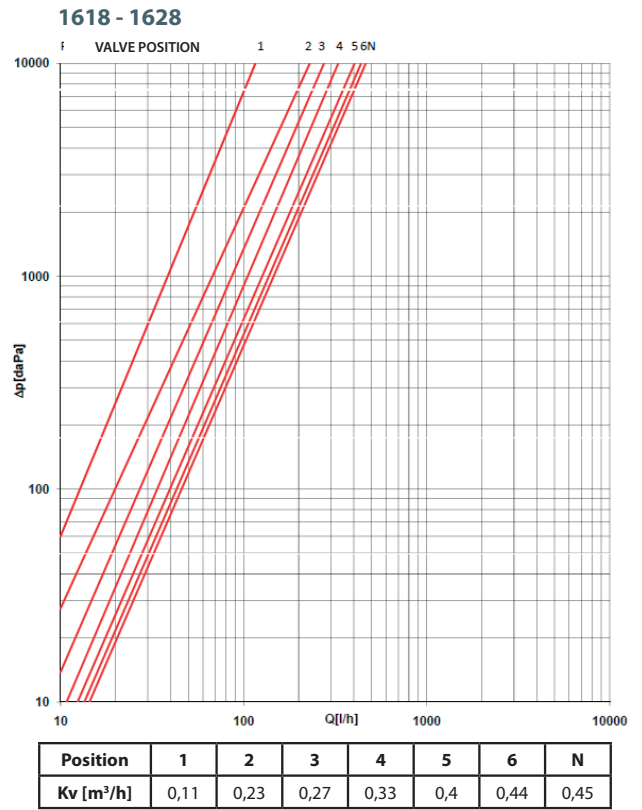
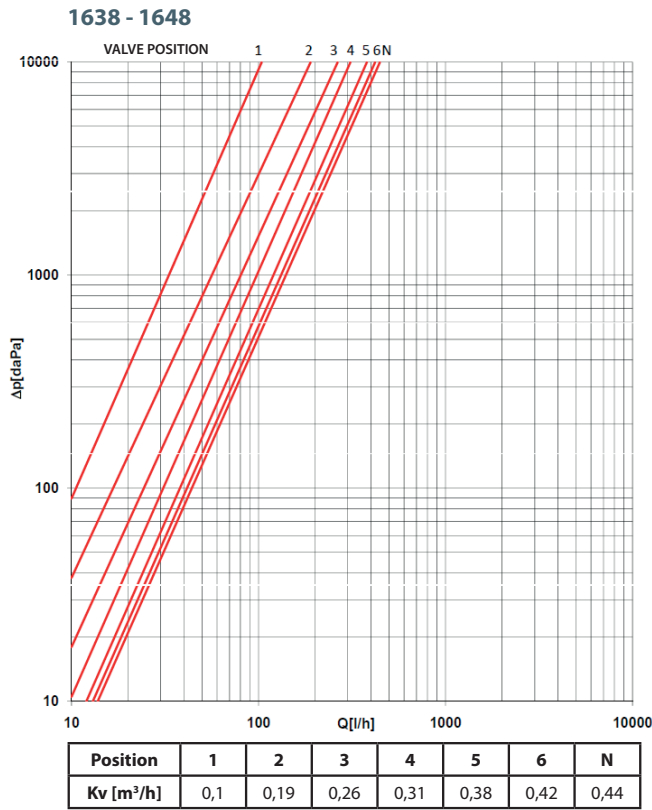

With installation of a thermostatic head for straight and angle versions the values are very close to each other for 3/8" and 1/2" sizes, as represented on the same graph.

6 DIMENSIONAL FEATURES

